

SPECIFIED LIVE LOADING REQUIREMENTS	
DISTRIBUTED LATERAL LOAD ①	25 kN/m <sup>2</sup>
TOP SLAB UNIFORMLY DISTRIBUTED LOAD ②	60 kN/m <sup>2</sup>
TOP SLAB POINT LOAD ③	70 kN
① BASED ON LATERAL LOADS FROM WATER TABLE AT SURFACE, SOIL AND SURCHARGE FROM WHEEL LOAD.	
② BASED ON THE WEIGHT OF A 2500KVA TRANSFORMER OF 73.87kN (7530kg).	
③ BASED ON WHEEL LOAD OF CL-625 ONTARIO TRUCK FROM CAN/CSA S6-06 LATEST EDITION.	

**NOTES:**

- A. HOLE FOR GROUND WIRE TO BE LABELED WITH GROUND SYMBOL USING GREEN PAINT. SYMBOL TO MEASURE 150mm x 150mm.  
SAMPLE:   
N.T.S.
- B. ALL DIMENSIONS IN MILLIMETERS UNLESS OTHERWISE SPECIFIED.
- C. CONCRETE - 35 MPa, AND SHALL MEET REQUIREMENTS OF CSA A23.1 LATEST EDITION FOR CONCRETE EXPOSED TO DE-ICING CHEMICALS. AIR CONTENT 5-8%, C1-CLASS OF EXPOSURE.
- D. REINFORCING STEEL - 400MPa, MINIMUM 40mm COVER.
- E. PAD SHALL BE PROVIDED WITH SWIFT LIFT SYSTEM TO ACCOMMODATE INSTALLATION AND REMOVAL.

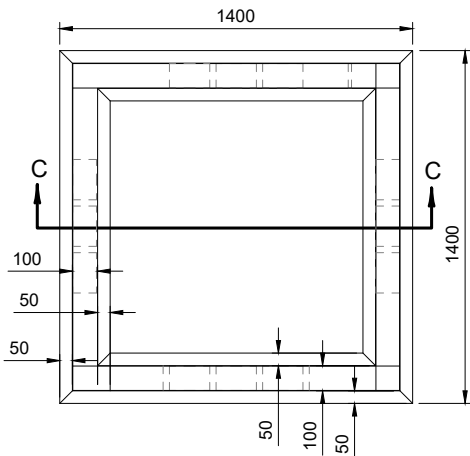

BASE (PLAN VIEW)

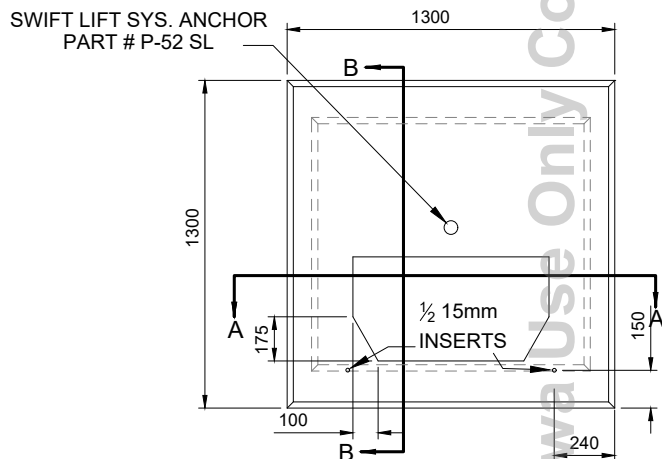

PAD (PLAN VIEW)

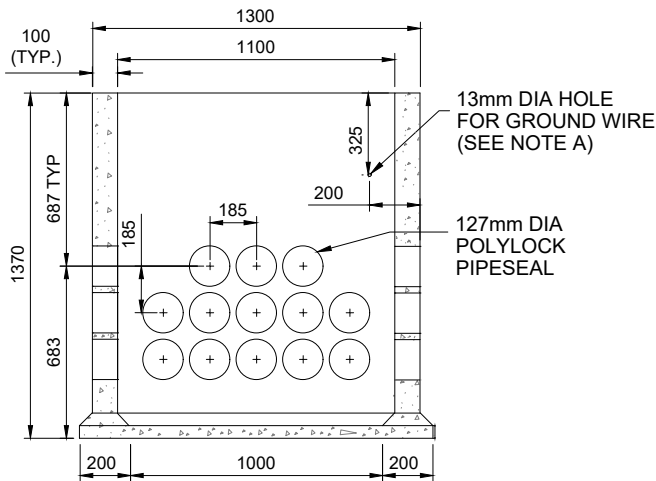

SECTION C-C TYPICAL

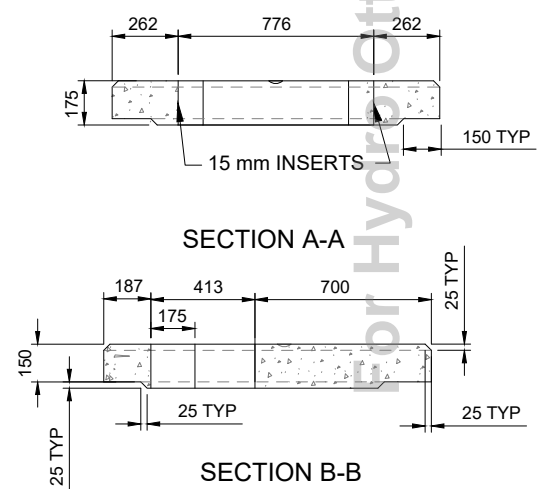

SECTION A-A

SECTION B-B

REVISIONS	PREP	CHKD	APPD
REV: 5 DATE: 2010-06-15 CHANGE: REV. SECTION B-B WITH THREADED INSERTS, BASE & PAD DIMENSIONS & TITLE	LB	CM	CSM
REV: 6 DATE: 2015-05-25 CHANGE: REVISED TABLE & NOTES	MM	RW	CSM
REV: 7 DATE: 2020-02-19 CHANGE: ADDED DUCTS TO FORMATION	EV	AK	BDH



www.HYDROOTTAWA.COM

PREP: G. MOLNAR
CHKD: C. MORAN
APPD: C. MALONE P.Eng
DATE: 2002-03-15
SCALE: N.T.S. @ ANSI A

TITLE	ENGINEERING SPECIFICATION		
	TRANSFORMER BASE & PAD		
	1 PHASE 25kVA - 167kVA		
	CONSTRUCTION DETAIL		
NO:	<b>UCS0003</b>		REV: 7
	1	OF	1