

**NOTES:**

- A. PRIMARY CABLES SHALL BE TRAINED:
  - A1. ACCORDING TO THE DIRECTION OF THE CABLE RUN.
  - A2. MINIMUM 3.5M LOOP REQUIRED LEFT IN BASE DURING INSTALLATION FOR TERMINATION PURPOSE.
  - A3. TO ENSURE UNENCUMBERED OPERATION OF THE LOAD BREAK ELBOWS.
- B. CABLE THAT ENTERS BASE FROM LEFT SHALL CONNECT TO H1A. CABLE THAT ENTERS BASE FROM RIGHT SHALL CONNECT TO H1B.
- C. CONCENTRIC NEUTRAL CONDUCTORS SHALL CONNECT TO SEPARATE GROUND BUS TERMINATION POINTS.
- D. 1/0 TO 1/0 AMPACT INSTALLED BETWEEN CONCENTRICS.
- E. PRIMARY CABLES SHALL BE TAGGED AND IDENTIFIED AS PER GCS0012 AND UTS0006.

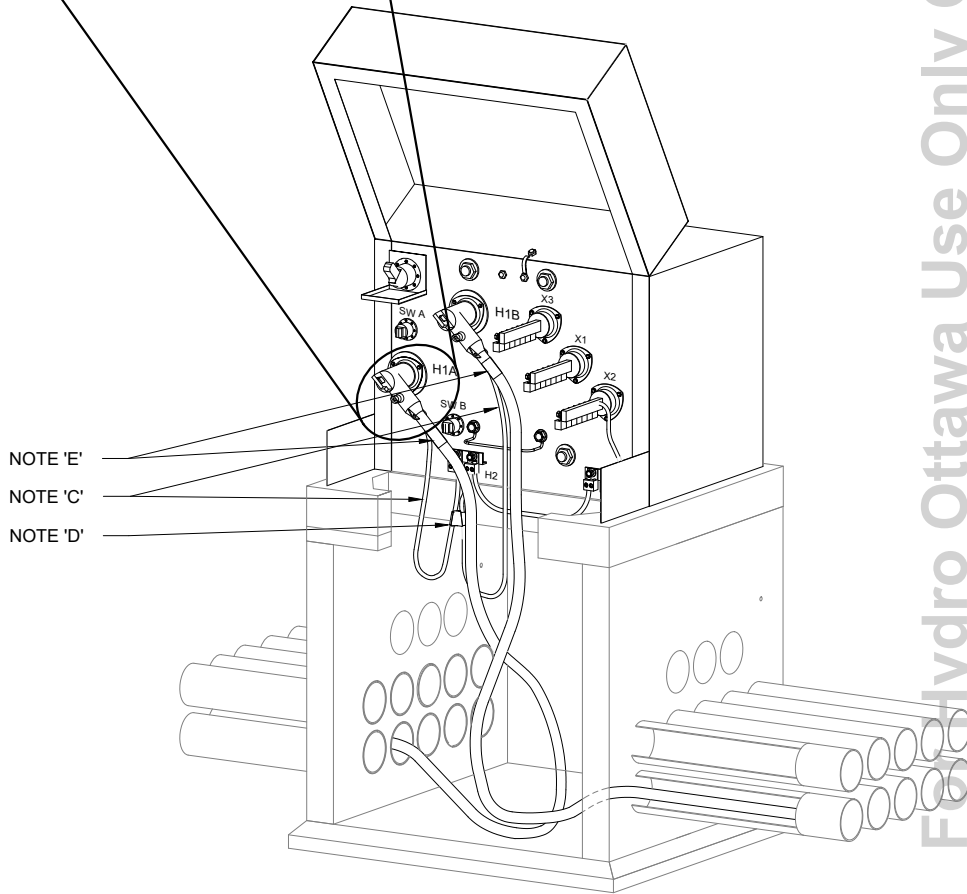
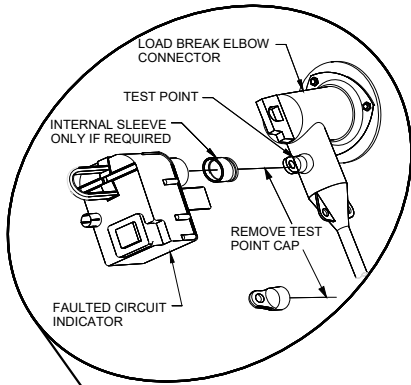

For Hydro Ottawa Use Only Copyright 2020

REVISIONS	PREP	CHKD	APPD
REV: 2 DATE: 2009-02-17 CHANGE: RE-DRAWN NOTE 'E' REVISED CABLE LAYOUT	CP	KM	CSM
REV: 3 DATE: 2010-05-27 CHANGE: TITLE CHANGE	FB	RW	CSM
REV: 4 DATE: 2020-02-27 CHANGE: MODIFIED DUCT LAYOUT	EV	AK/ MW	BDH

**HydroOttawa**  
www.HYDROOTTAWA.COM

PREP: G. MOLNAR
CHKD: C. MORAN
APPD: C. MALONE P. Eng
DATE: 2002-07-22
SCALE: N.T.S. @ ANSI A

TITLE	ENGINEERING SPECIFICATION		
	TRANSFORMER PRIMARY WIRING		
	1 PHASE PADMOUNT		
	WIRING DETAIL		
NO:	<b>UTS0005</b>		REV: 4
	1	OF	1